



Enclosure Type: Trident S2

Dimensions (overall): 450x550x730mm (LxWxH)

Dimensional detail: L(450mm) – L1(400mm) – B(500mm) – B1(450mm)
– H(650mm) – V(250mm) – V1(150mm) – U(550mm) – U1(500mm)

TRIDENT RANGE OF THREE-PHASE/SINGLE-PHASE TRANSFORMER CASES

- All dimensions given in millimetres
- Standard finish: Hammer grey or RAL 7032
- All cases supplied in kit form and individually packed
- Ratings available: IP20 IP23 IP44 IP54 IP65
- Features: Incorporated into the design of the case in an ingenious method of construction, allowing for adjustable transformer and case fixing centres
- Base plates available on request

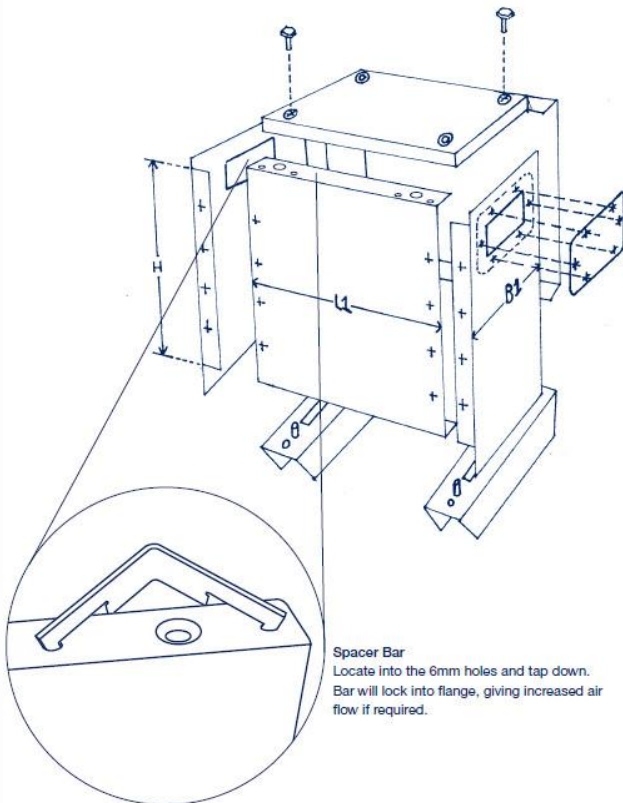

Spacer Bar
Locate into the 6mm holes and tap down.
Bar will lock into flange, giving increased air flow if required.

