

Victron SmartShunt Connection

DC connection to the negative post of the battery

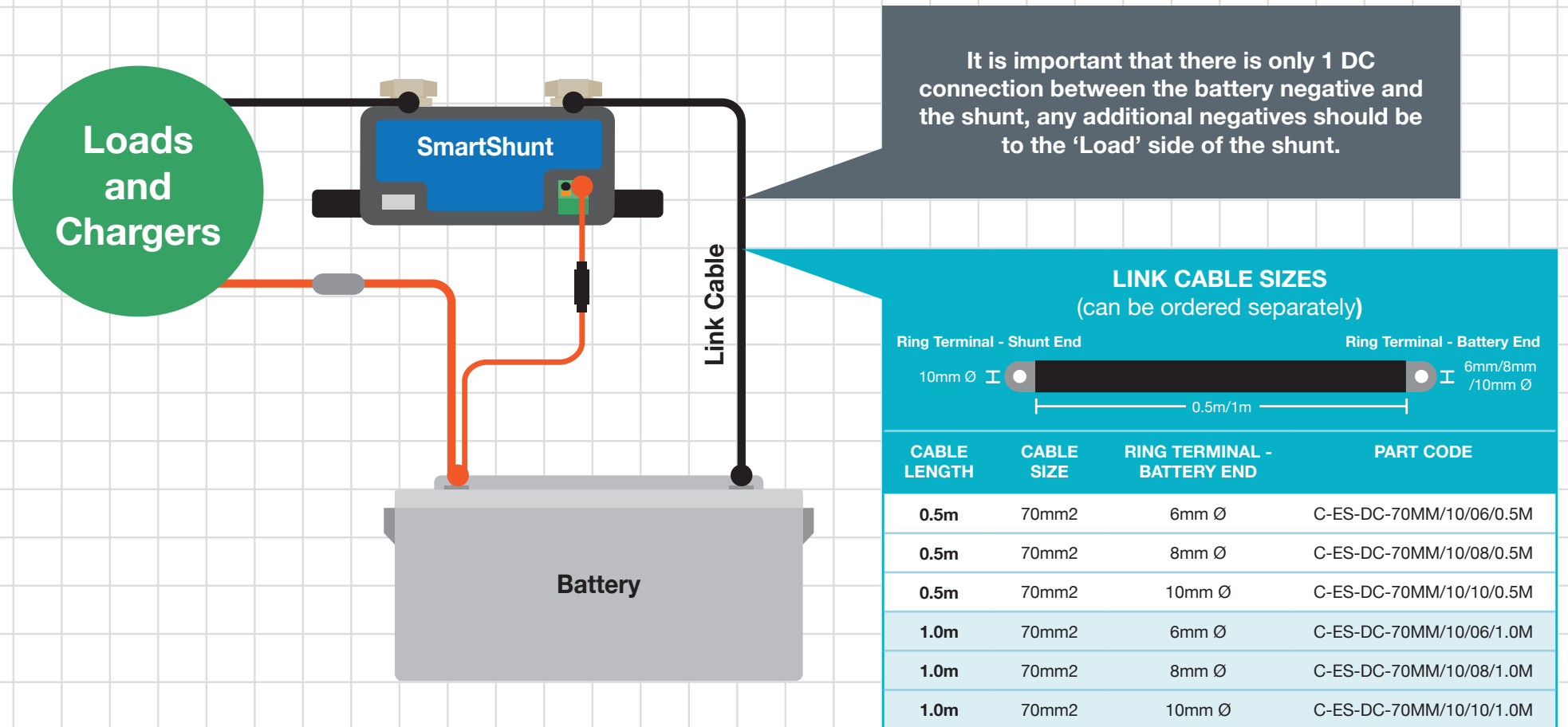

Other lengths, cable size and terminations available on request.
Please contact us with any requirements.

This is a general arrangement drawing and is supplied for illustrative purposes only. This is not a wiring diagram and should not be viewed or used for installation purposes. Always refer to the equipment manufacturers installation requirements and guidelines and seek professional installation and guidance where required.



tel: +44 (0)1634 290772
email: sales@energy-solutions.co.uk web: www.energy-solutions.co.uk