



victron energy

B L U E P O W E R

MultiPower: environment friendly all-in-one hybrid energy

The case for a hybrid system

Per Watt AC-power, an inverter is generally more expensive than a generator. So why would one add an inverter to an AC-generator system?

Apart from the obvious advantage of “silent AC-power”, there are other major considerations why it is attractive to add a Multi or Quattro inverter/charger to a system with ac-generator:

- More power: generator **plus** inverter instead of generator **or** inverter
- Reduces fuel consumption (and pollution) by a factor three or more
- Cost and time savings as a result of reduced maintenance
- Extended generator life
- 24/7 availability of AC power

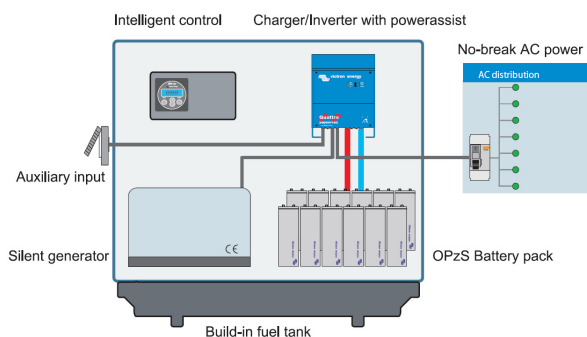

Block diagram

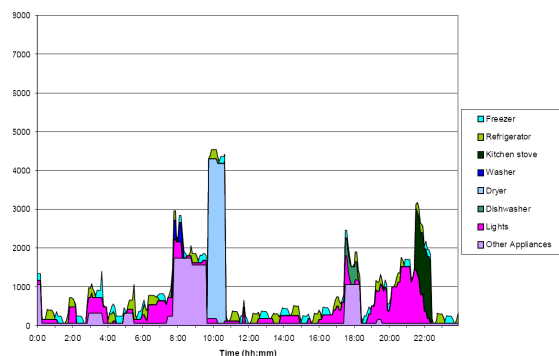

Typical daily load distribution of a household

More power: generator + inverter

The VE Quattro inverter-chargers feature PowerAssist, a unique capability of supplementing power to the generator. Insufficient generator power is immediately compensated for by the inverter/charger with extra power from the battery. The total output power of the system can reach up to 3 times the nominal generator power for temporary heavy loads, and problems related to insufficient generator power are solved once and for all. Electric cooking, washing machines, power tools, water pumping and pressurisation... there are virtually no limitations.

Fuel savings and less pollution

Tests have shown that a generator is incredibly inefficient when operating at low load (see references below). By combining a generator with an inverter/charger and batteries, efficiency can be increased as follows:

- By operating the generator in parallel with the inverter/charger, peak power available is equal to the sum of generator power and inverter power. A smaller generator can therefore be installed.
- When the generator is operating, any available power that is not needed to supply the load will be used to recharge the batteries. The generator will therefore always operate at maximum efficiency.

Cost and time savings as a result of reduced maintenance, and extended generator life

In most applications the generator, instead of running 24/7, will operate only a few hours per day.

24/7 availability of AC power

With AC power available from both the generator and the inverter, the MultiPower has built-in redundancy.

Preassembled and ready for use

The MultiPower includes all controls for fully automatic operation. Solar or wind power can be added to further reduce generator run hours.

More information

Several downloads are available on our website:

- Victron Marine Generator Test, in particular chapter 4: “The case for a hybrid system”
- “Using the Phoenix MultiPlus to reduce operating cost of a generator”
- “How to reduce the cost of supplying power to an off-grid BTS”

Configure or assemble your own MultiPower

Please contact us for more information.

MultiPower



Victron Energy B.V. / De Paal 35 / 1351 JG ALMERE / The Netherlands

Phone: (+31) (0)36 535 97 00 / Fax: (+31) (0)36 535 97 40 / www.victronenergy.com / e-mail: sales@victronenergy.com



MultiPower



A few examples of MultiPower configurations

MultiPower	5kVA/600Ah	13kVA/800Ah	18kVA/1000Ah	20kVA/1000Ah	27kVA/1200Ah
MAXIMUM OUTPUT	(5kVA inverter)		(Parallel operation of AC generator and Quattro(s))		
Max. output power (kVA / kW)	5 / 4,25	13 / 11	18 / 15	20 / 16	27 / 23
GENERATOR	DC generator		AC generator		
Nominal output voltage	24V DC		230VAC ± 6% single-phase – 50Hz ± 4%		
Continuous output power (kW)	4,8kW/200A DC	7	7	8	10
OUTPUT – Inverter mode	230V ± 2% single-phase – 50Hz ± 0.1%				
Nominal AC output voltage	230V ± 2% single-phase – 50Hz ± 0.1%				
Cont. output power at 25 °C (kVA / kW)	5 / 4,25	5 / 4,25	10 / 8,5	10 / 8,5	15 / 12,75
Cont. output power at 40 °C (kW)	3,35	3,35	6,7	6,7	10
Peak power (kW)	7,5	7,5	15	15	22,5
GENSET	Mechanical				
Engine (4-stroke direct injection diesel)	Air cooled	Air cooled	Air cooled	Air cooled	Oil cooled
Model	Ruggerini RY 103	Ruggerini RY 125	Ruggerini RY 125	Lombardini 9LD625.2L	Deutz FL2L2011
Cylinders / displacement cm ³	1 / 401	1 / 505	1 / 505	2/ 1.248	2 / 1.550
Rating ISO 3046/1 1FN (kW / HP)	6,6 / 9 @3000rpm	8,1 / 11 @3000rpm	8,1 / 11 @3000rpm	10,3 / 14 @1500rpm	12,6 / 17 @1500rpm
Fuel consumption, nominal load (L/h)	1,6	2,3	2,3	2,7	3,4
Fuel consumption, nominal load (g/kWh)	220	230	230	230	220
Governor type	Mechanical				
Electric start, starter battery, alternator	Standard				
Alternator	DC		SINCRO single-phase AVR regulated		
Model / kW	ET2MCD / 4,8	EK2LBA / 7	EK2LBA / 7	SK160SA1 / 8,2	SK160CB1 / 12,8
Voltage regulation	AVR (electronic voltage regulation)				
INVERTER-CHARGER	AVR (electronic voltage regulation)				
Model	Inverter 24/5000		Quattro 24/5000/120 ¹⁾		
Configuration	1 unit single	1 unit single	2 units parallel	2 units parallel	3 units parallel
Max. charge current (A)	200	120	120	240	360
BATTERY	OPzS flooded tubular plate, 12 cells, 24V				
Type	OPzS flooded tubular plate, 12 cells, 24V				
Cell capacity (Ah @ C10)	600	800	1000	1000	1200
CONTROLS	Auto/manual start/stop with oil pressure, temperature and voltage protection				
Generator controller	Auto/manual start/stop with oil pressure, temperature and voltage protection				
Output voltage indicators	Voltage – Amps – Frequency				
Tank level gauge	Standard				
Hour counter	Standard				
Battery monitor	BMV-600 ¹⁾				
External emergency stop button	Standard				
ELECTRICAL CONNECTIONS	Standard				
External AC in (grid or emergency)	For external 230V AC source (MCB protected)				
AC out 1	Inverter or/and genset output (MCB protected)				
AC out 2	Genset only output (MCB protected)				
ENCLOSURE	Standard				
Common characteristics	Chassis mounted 3-compartment enclosure with lifting ring, designed for outdoor use				
Material, colour	Assembled steel soundproofing enclosure, blue RAL 5012, chassis black				
Access doors	3 doors with single-key locks, left (genset), front (battery), right (inverter-chargers & controls)				
Engine silencer & exhaust	Integrated in enclosure				
Ventilation	Extractor fans in genset and battery compartments, air outlets on back side				
Fuel tank	150L chassis tank				
Dimensions (hwxwd, mm)	1740 x 2000 x 1200				
Approx. weight (excl. Fuel, kg)	1.300	1.500	1.700	1.900	2.200
Approx. noise (open field, dB(A) @ 7m)	65	65	65	65	60

1) for more details on Quattro Inverter-chargers and BMV-600 Battery monitor, please refer to our specific data sheets

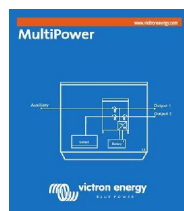

Victron Energy B.V. / De Paal 35 / 1351 JG ALMERE / The Netherlands

Phone: (+31) (0)36 535 97 00 / Fax: (+31) (0)36 535 97 40 / www.victronenergy.com / e-mail: sales@victronenergy.com