

delta performance

F25 / F35 / F45

***Installation , Operating &
Servicing Instructions***

delta
performance



1 INTRODUCTION	2
1.1 People who should read these instructions	2
1.2 Symbols	2
1.3 Applicable standards	2
1.4 Warnings	2
2 INSTALLATION	3
2.1 Boiler room	3
2.2 Connections	3
2.4 Electrical connections	6
3 STARTING UP	7
3.1 Filling the heating and domestic hot water circuits	7
3.2 Troubleshooting the burner	7
4 SERVICING	7
4.1 Recommendation	7
4.3 Servicing the oil boiler	7
4.4 Servicing the safety devices	7
4.4 Servicing the burner	8
4.6 Emptying the boiler	8
4.7 Spare parts	8
5 DESCRIPTION	9
5.1 Overview	9
5.2 Description of operation	9
5.3 Build features	10
6 TECHNICAL SPECIFICATIONS	11
6.1 Effective dimensions	11
6.2 Maximum operating conditions	11
6.3 Domestic hot water performance	11
6.4 Boiler without burner	11
7 USER GUIDE	14
7.1 Using the boiler	14
7.2 Boiler room	15

1.1 PEOPLE WHO SHOULD READ THESE INSTRUCTIONS

These instructions should be read by:

- the specifying engineer
- the installation engineer
- the user
- servicing technicians

1.2 SYMBOLS

The following symbols are used in these instructions:



Essential to ensure that the system works properly.



Essential for personal safety and environmental protection.



Danger of electrocution.



Danger of burns.

1.3 APPLICABLE STANDARDS

The products have been granted the “EC” certificate in accordance with the standards in force in different countries (European Directives, 92/42/EEC “efficiency” and 90/396/ECC “gas devices”). These products have also been granted the Belgian “HR+”(gas boilers) and “OPTIMAZ” (oil boilers) marks.



1.4 WARNINGS

These instructions are an integral part of the equipment to which they refer and the user must be provided with a copy.

The product must be installed and serviced by qualified engineers, in compliance with current standards.

ES cannot accept liability for any damage resulting from incorrect installation or from the use of components or fittings not specified by ES.



Any failure to follow instructions relating to tests and test procedures may result in personal injury or risks of pollution.



Because of their high level of performance our boilers produce flue gas discharge at low temperatures. This can cause condensation in some chimney flues. Your installing engineer will advise you whether you need to install a flue pipe in your chimney.

N.B.

ES reserves the right to change the technical specifications and components of its products without prior notice.

2 INSTALLATION

2.1 BOILER ROOM

2.1.1 ACCESSIBILITY

The boiler room must be large enough to allow proper access to the boiler. The following minimum distances (mm) around the boiler are required:

- at the front	500	- at the sides	100
- at the rear	150	- above	700

2.1.2 VENTILATION

The boiler room must be fitted with top and bottom vents as shown in the table below.

2.1.3 BASE

The boiler must be laid on a base made of non-combustible materials.

2.2 CONNECTIONS

2.2.1 CHIMNEY CONNECTION

The boiler can be connected to a suitable flue or to chimney by a metal pipe rising at an angle from the boiler to the chimney. It must be easily removable in order to give access to the flue pipes when servicing the boiler. A draught regulator must be installed on the chimney in order to stabilise negative pressure.



Because of their high level of performance our boilers produce flue gas discharge at low temperatures. This can cause condensation in some chimney flues. Your installing engineer will advise you whether you need to install a flue pipe in your chimney.

- A. Top vent
- B. Bottom vent
- C. Draught regulator
- D. Inspection cover
- E. Chimney height
- F. Chimney diameter

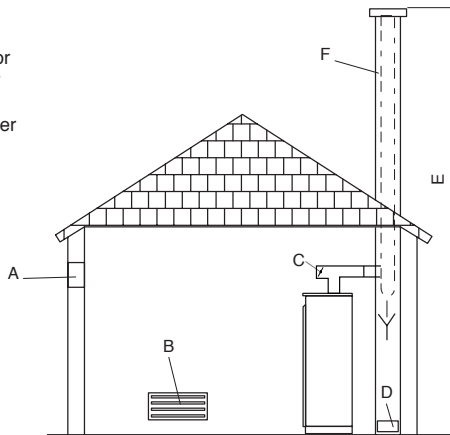

Fig. 1: Boiler room ventilation and chimney connection

Ventilation		F25	F35	F45
Min. fresh air requirement	m ³ /h	50/66	66/90	84/122
Top vent (A)	dm ²	2	2	2
Bottom vent (B)	dm ²	1,5	1,5	1,5
Chimney				
E = 5m	Ø min.F mm	158/182	182/213	208/248
E = 10m	Ø min.F mm	133/153	153/179	175/209
E = 15m	Ø min.F mm	130/138	138/162	158/188



Important
Boilers must be installed by an approved engineer, in accordance with current local standards and regulations.

2.2.2 CENTRAL HEATING CONNECTION

2.2.2.1 Examples of basic circuit configurations

The drain cock and safety valve must be connected to the waste water disposal system.

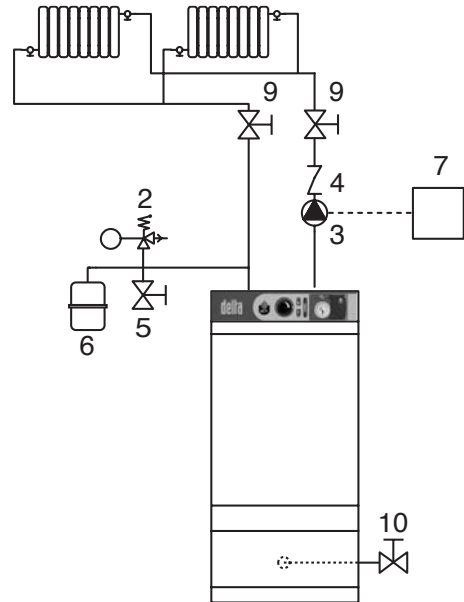

Fig. 2: Hydraulic diagram showing circulator controlled by a room thermostat.

2 INSTALLATION

2.2.2.2 ES hydraulic kit

ES offers an optional pre-assembled hydraulic kit comprising:

- A circulator.
- A motorised 3-way manual valve.
- Connecting pipes including an optional second circuit.
- Two isolation valves.
- Connectors for mounting the safety valve with pressure gauge and the filling valve to the right or left of the expansion tank.

2.2.2.3 Discharge

The drain cock and safety valve must be connected to the waste water system in accordance with current regulations.



Fig. 4: Assembly with the ES hydraulic kit

2.2.3 DOMESTIC HOT WATER CONNECTION

2.2.3.1 Pressure reducer

If the water mains pressure is greater than 6 bar, a pressure reducer calibrated to 4.5 bar must be fitted.

2.2.3.2 Safety unit

The tank safety unit must be ES approved and calibrated to 7 bar. The valve discharge must be connected to the waste water system in accordance with current regulations.

2.2.3.3 Domestic hot water expansion tank

Installing a hot water expansion tank avoids any risk of pressure surges due to waterhammer.

2.2.3.4 Hot water circulation

If the tank is located a long way from the point of use, then installing a closed recirculation circuit ensures that a faster supply of hot water is always available.

2.2.3.5 Description

1. Safety unit
2. Pressure reducer
3. Thermostatic mixing valve
4. Hot water circulator
5. Non-return valve
6. Domestic hot water type expansion tank
7. Inlet valve
8. Draw-off valve
9. Bleed valve

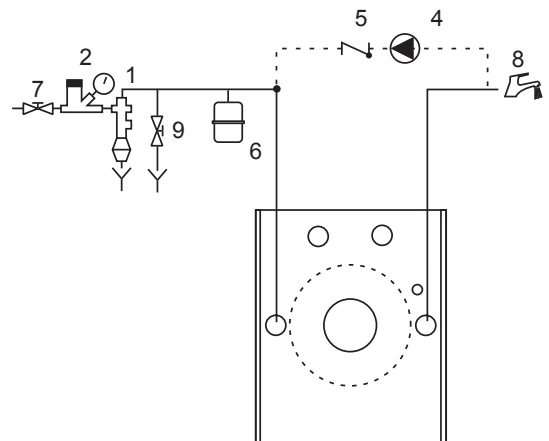

Fig. 5a: Connection without thermostatic mixing valve

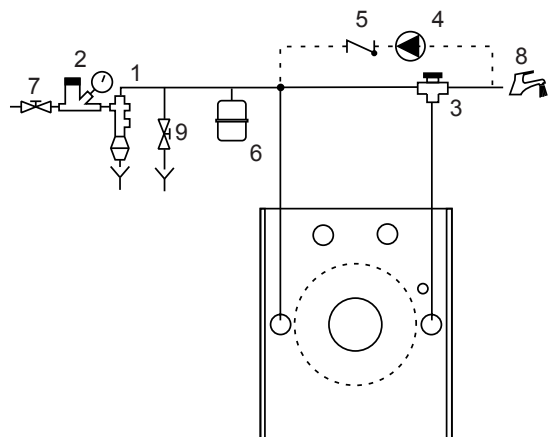

Fig. 5b: Connection with thermostatic mixing valve



IMPORTANT

As a safety measure against burns, we strongly advise installing a thermostatic mixing valve (recommended temperature: 60° C).

This is available as an optional accessory

Safety unit	Ø 3/4"
Pressure reducer	Ø 3/4"
Thermostatic mixing valve	Ø 3/4"
Expansion tank	5 litres

2 INSTALLATION

2.4 ELECTRICAL CONNECTION

2.4.1 DESCRIPTION OF POWER SUPPLY

The boiler operates on single phase 230 V – 50 Hz. An on-off switch box with 6 A fuses must be fitted outside the boiler to allow power to be shut off during servicing and before any repairs are carried out on the boiler.

2.4.2 COMPLIANCE

Boiler installation must comply with current local standards and legislation.

2.4.3 SAFETY

The stainless steel tank must be earthed separately.

2.4.4 BURNER ELECTRICAL CONNECTION

The burner is powered through a 3-core cable, which is plugged into the connector in the lower right hand corner of the burner chamber plate. Details of how to connect it up are given in the technical instructions for the burner.



It is important to switch the boiler off before carrying out any work.

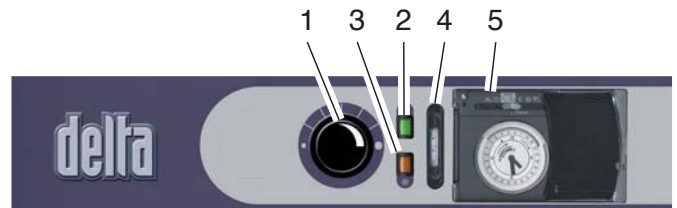

Fig. 9 Control panel

- | | |
|--|-----------------|
| 1. Boiler thermostat (60/90° C) | M. Brown |
| 2. On/off switch | O. Orange |
| 3. Summer/Winter selector switch | N. Black |
| 4. Thermometer | B. Blue |
| 5. Controller (optional) | T. Green-yellow |
| 6. Safety thermostat (95° C max.) | G. Grey |
| 7. Safety thermostat (103° C max.) | J. Yellow |
| 8. Plug for power and control | |
| 9. Central heating circulator connection | |
| 10. Burner connection | |
| 11. Room thermostat | |

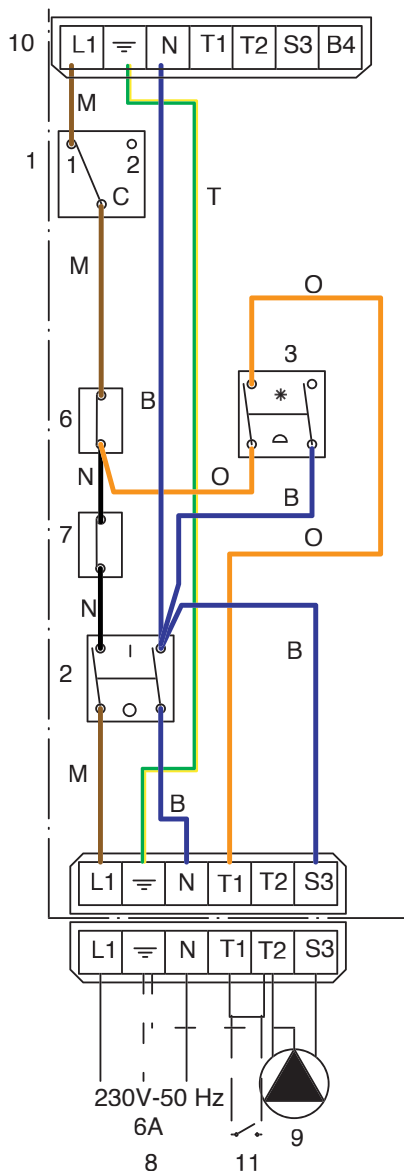

Fig. 10 a: Boiler wiring

3.1 FILLING THE HEATING AND DOMESTIC HOT WATER CIRCUITS

1. Fill the domestic hot water circuit and bring it up to pressure.



IMPORTANT
The hot water tank must be pressurised before the heating circuit is filled.

2. Fill the heating circuit taking care not to exceed the 2 bar pressure limit.
3. Bleed the air from the top of the boiler.
4. After bleeding the air out of the system, bring the pressure up to the static pressure (height) plus 0.5 bar: 1.5 bar = 10 m – 2 bar = 15 m.
5. Check the power connection, the boiler room ventilation and ensure that there are no leaks in the flue gas discharge pipes.
6. Set the thermostat (1) to between 60 and 90° C.

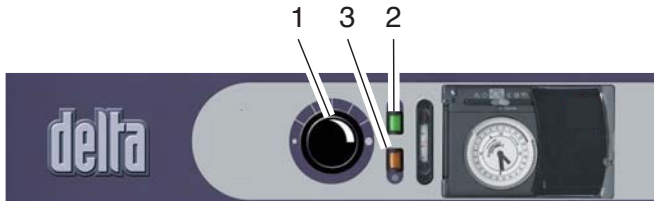

Fig. 11: Control panel

7. Set the Summer/Winter selector switch (3) to the desired position.
8. Switch the on/off switch (2) to the ON position.
9. Check the pressure of the gas supply when starting up.
10. For the oil burner check the oil supply (and return). Carry out any bleeding, measuring and adjustment work which may be necessary.

3.2 TROUBLESHOOTING THE BURNER

3.2.2 OIL BURNER

Please refer to the servicing and troubleshooting instructions for the burner.



Before carrying out any servicing or repair work, switch the power off at the mains switch fitted in the boiler room by the electrician.

4.1 RECOMMENDATION

ES recommend that boilers should be serviced at least once a year. The burner must be serviced and tested by a competent engineer.

4.2 SERVICING THE BOILER

- 1 - Switch the power off at the mains switch outside the boiler and close the oil tap.
- 2 - Set the on/off switch on the control panel to the OFF position.
- 3 - Release and remove the chimney flue (1) to free the top of the boiler.
- 4 - Remove the jacket top (2) and lift off the flue reducer (3).
- 5 - Remove the baffles (4) from the flue pipes (5) for cleaning. Replace them if they are in poor condition.
- 6 - Remove the chamber plate (6).
- 7 - Brush the flue pipes (5).
- 8 - Clean the burner chamber (7) and the burner (8).
- 9 - Check the insulation on the chamber plate (6)

1. Chimney flue
2. Jacket cover
3. Chimney flue reducer
4. Baffles
5. Flue pipes
6. Chamber plate
7. Combustion chamber
8. Burner

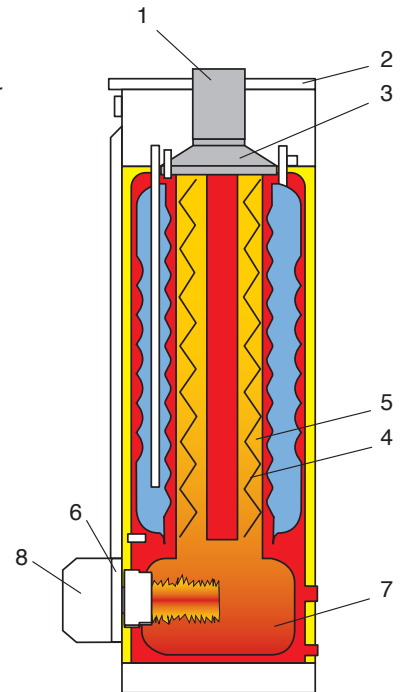

Fig. 12: Description of the main components which require servicing.

4.3 SERVICING THE OIL BOILER

- Switch the power off at the mains switch outside the boiler and close the oil inlet.

4.4 SERVICING THE SAFETY DEVICES

- Check that all thermostats and safety devices are working properly: boiler thermostat, cut-off thermostat and manually reset safety thermostat.
- Check the safety valves on both the central heating and the hot water circuits.

4 SERVICING

4.5 SERVICING THE BURNER

4.5.1 OIL BURNER

- Check the main filter on the oil line and clean it if necessary.
- Check the nozzle line: check, clean or change the nozzle and filter, check that it is clean and that the electrodes and flame holder are properly set.
- Replace the whole unit and check that the safety devices are working properly
- Adjust the combustion parameters.

4.6 EMPTYING THE BOILER

4.6.1 EMPTYING THE PRIMARY CIRCUIT (CENTRAL HEATING):

1. Switch the power to the boiler off at the mains switch installed by the electrician.
2. Close the boiler system's isolating valves (1).
3. Connect a hose to the drain cock (2).
Make sure that it is properly attached.
4. Open the drain cock and let the hot water drain out.



5. When the boiler is empty, return the valves to their initial positions

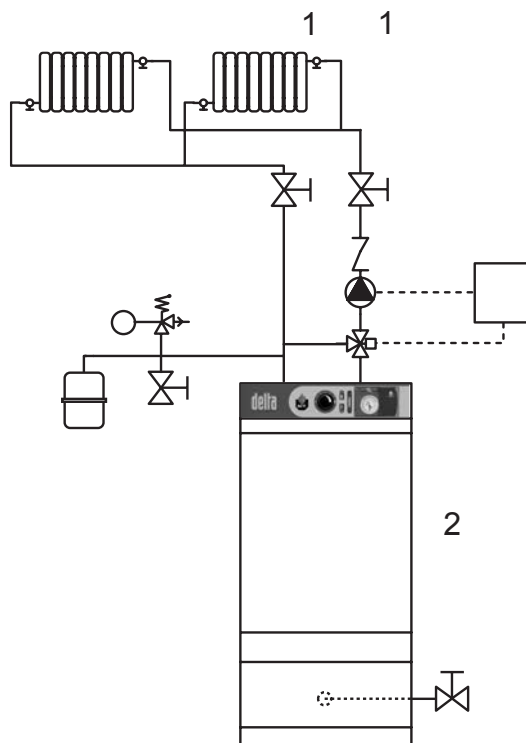

Fig. 13a: Emptying the primary circuit

4.6.2 EMPTYING THE DOMESTIC HOT WATER TANK:

1. Switch the mains power to the boiler off at the external switch installed by the electrician.
2. Remove the pressure from the primary circuit.
3. Close valves (A) and (B).
4. Open valves (C) and (D) (first C then D).
5. Let the water drain away.



6. After emptying, return the valves to their initial positions.



To allow the tank to be emptied, valve (C) must be situated at ground level.

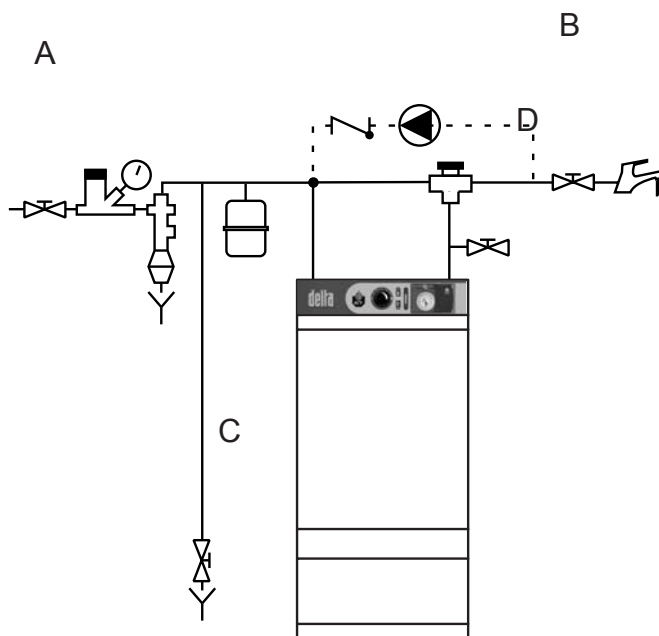

Fig. 13b: Emptying the hot water circuit

4.7 SPARE PARTS

Please refer to the specific document available from ES or your distributor.

5 DESCRIPTION

5.1 OVERVIEW

- Combination boiler (central heating and domestic hot water).
- Designed for connection to a chimney.
- TANK-IN-TANK indirect storage type domestic hot water production.
- Fittings required to connect the hydraulic kit for feeding the heating circuit (available as an optional extra).
- Control panel with on/off switch, adjustable thermostat, thermometer, Summer/Winter selector and knockout for fitting integrated control system (optional).
- DELTA Performance F25, F35 and F45 models - with effective outputs adjustable between 22 and 54 kW - are shipped with an

5.2 DESCRIPTION OF OPERATION

5.2.1 THE TANK-IN-TANK CONCEPT

The DELTA Performance series differs from traditional hot water producers in that it has a ring-shaped tank immersed in the primary fluid contained in the outer body. When hot water from the central heating system or the domestic hot water system is needed, the thermostat starts up the burner. The combustion gases quickly heat up the primary fluid, thus creating a natural circulation around the tank.

5.2.2 INDIRECTLY HEATING DOMESTIC HOT WATER

This circulation allows easier heat exchange between the primary fluid and the domestic water, all over the tank surface. The corrugations on the inner and outer shells of the ring-shaped tank increase the area of heat exchange still further and thus speed up the process of heating the domestic water.

5.2.3 EASY TO SET AND SAFETY ASSURED

With a single command, the water temperature of both the primary circuit and the domestic hot water circuit can be set by the adjustable thermostat situated underneath the tank in the primary circuit. A cut-off thermostat, placed on the top of the boiler automatically switches off the burner when the temperature of the water in the primary circuit reaches 95° C. A manually reset safety thermostat switches off the burner if the temperature reaches 103° C.



Fig. 14: Stainless steel domestic hot water tank

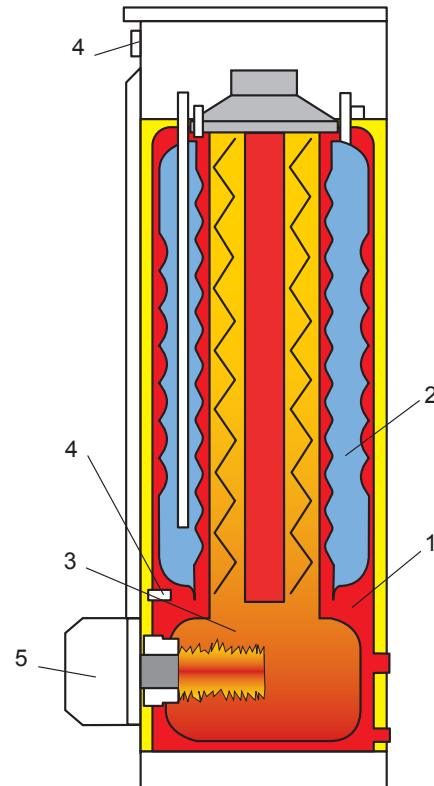

Fig. 15: Brief description of the boiler

- | | |
|-----------------------|-----------------------|
| 1. Primary fluid | 4. Control thermostat |
| 2. Domestic hot water | 5. Burner |
| 3. Combustion chamber | |

5 DESCRIPTION

5.3 BUILD FEATURES

5.3.1 OUTER BODY

The outer body containing the primary fluid is made of STW 22 steel.

5.3.2 TANK-IN-TANK TYPE EXCHANGER ACCUMULATOR

The ring-shaped inner tank with its large heating surface, used for producing domestic hot water, is built using Chrome/Nickel 18/10 stainless steel. It is corrugated all the way up to the top using an exclusive production process and entirely argon arc welded using the TIG (Tungsten Inert Gas) method.

5.3.3 COMBUSTION GAS CIRCUIT

The combustion gas circuit is protected by a coat of paint. The combustion gas circuit comprises:

5.3.3.1 Flue pipes

Depending on output, the various DELTA Performance models contain either 4 or 8 steel flue pipes with an inner diameter of 64 mm. Each pipe is fitted with a special steel baffle designed to improve heat exchange and reduce the flue gas temperature.

5.3.3.2 Combustion chamber

All DELTA Performance models feature a fully water-cooled combustion chamber.

5.3.4 INSULATION

The boiler body is fully insulated by rigid polyurethane foam with a high thermal insulation coefficient. This is sprayed onto the tank without using any CFCs.

5.3.5 JACKET

The boiler is covered by a steel jacket which has been scoured and phosphated before being stove finished at 220° C.

1. Inner ring-shaped tank containing the domestic hot water
2. External body containing central heating circuit
3. Insulation
4. Jacket
5. Flue pipes
6. Baffles
7. Thermostat adjustable between 60° and 90° C
8. Lower central heating return
9. Combustion chamber
10. Chamber plate
11. Emptying the boiler
12. Upper central heating flow pipe and return
13. Chimney connection
14. Control panel
15. Domestic hot water outlet
16. Domestic cold water inlet
17. Cut-off thermostat 95° C / Thermometer
18. Manually reset 103° C safety thermostat
19. Oil burner

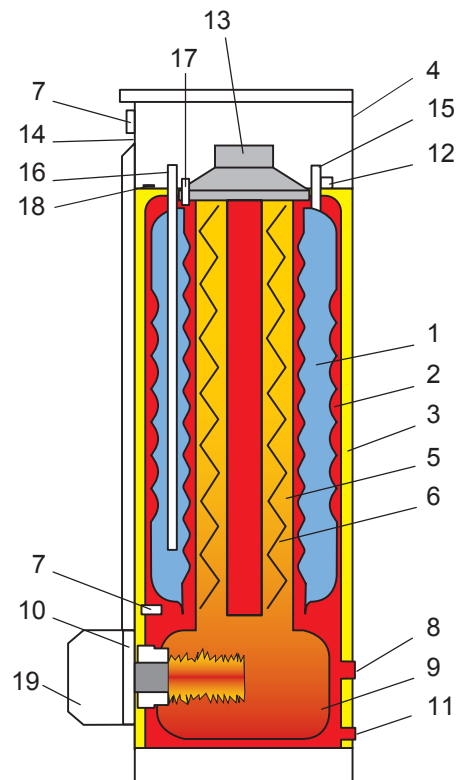

Fig. 16: The boiler



IMPORTANT

For assembly, the various settings, start-up and servicing please see the technical instructions which come with the burner.

5.3.7 CONTROL PANEL (FIG. 17)

- 1 - Thermostat adjustable between 60° and 90° C
- 2 - On/off switch
- 3 - Summer/Winter selector switch
- 4 - Thermometer
- 5 - Knockout for control system (optional).

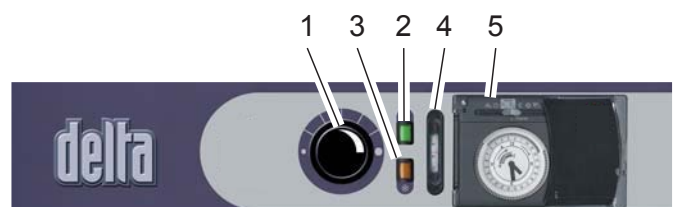

Fig. 17: Control panel

6 TECHNICAL SPECIFICATIONS

6.1 EFFECTIVE DIMENSIONS

Units are shipped fully assembled, tested and packed on a timber base with shockproof edges and protected by a heat-shrunk plastic film. On reception and after unpacking, check the equipment for any damage. For transportation purposes, please see the weights and dimensions given below:

6.2 MAXIMUM OPERATING CONDITIONS

Maximum operating pressure (tank full of water)

- Primary circuit: 3 bar
- Secondary circuit: 10 bar

Test pressure (tank full of water)

- Primary circuit: 4.5 bar
- Secondary circuit: 13 bar

Operating temperature

- Maximum temperature: 90° C

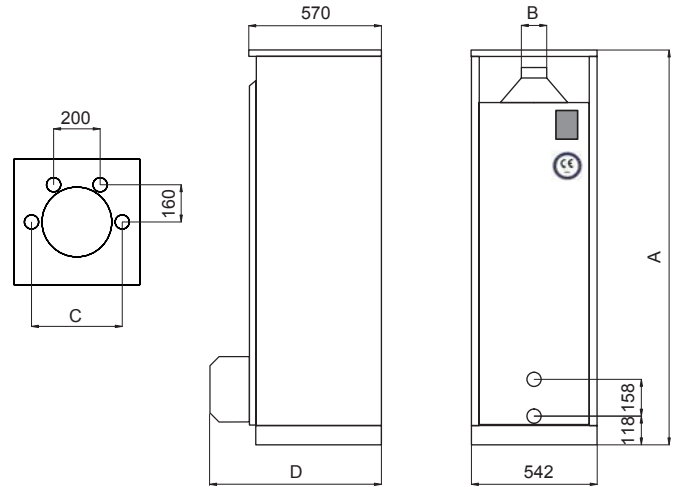

Fig. 18: Effective dimensions

Dimensions	F25	F35	F45
A	1497	1697	1497
B	130	130	150
C	360	360	390
D	818	818	818
Kg	157	168	180

6.3 DOMESTIC HOT WATER PERFORMANCE

Domestic hot water performance			F25	F35	F45
OPERATING AT 80° C					
Peak flow at 40° C	($\Delta T = 30^\circ C$)	l/10'	268	285	316
Peak flow at 40° C	($\Delta T = 30^\circ C$)	l/60'	806	1035	1284
Continuous flow 40° C	($\Delta T = 30^\circ C$)	l/h	645	900	1161
OPERATING AT 80° C					
Start-up		minutes	32	29	16
After drawing off 140 l at 45° C		minutes	15	11	9

6.4 BOILERS WITHOUT BURNER

		25	35	45
Heat release rate (input)	kW	25/33	33/45	42/61
Effective rated output (output)	kW	22/29	29/40	38/54
Maintenance loss at 60°C as % of rated value	%	1,36/1	1/0,79	0,8/0,56
Total capacity	l	157	178	132
Primary circuit capacity	l	83	104	70
Central heating connection	Ø	1"	1"	1"
Domestic hot water connection	Ø	3/4"	3/4"	3/4"
Hot water tank heat exchange surface	m ²	1,59	1,59	1,99
Weight when empty	Kg	145	156	168

7.1 USING THE BOILER

7.1.1 LEARNING YOUR WAY AROUND THE CONTROL PANEL (Fig. 23)



Before carrying out any work on the boiler, switch the power off at the mains switch installed in the boiler room by the electrician. Turn the ON/OFF switch on the control panel off.
(item marked 2, Fig. 23)

1 - Thermostat adjustable between 60 and 90° C (item marked 1, Fig. 23)
Central heating systems are generally designed to operate at a maximum of 80° C. When used at lower temperatures, a 3-way mixer valve installed on the heating flow pipe (see Fig. 3 on page 3) allows the temperature to be set manually or, if you decide to install a regulator (§ 2.2.4), automatically.
We recommend that you set the thermostat to the maximum values to get the best out of the domestic hot water system.



There is a risk of burns from hot water!

The water stored in the domestic hot water tank in the boiler can be at a very high temperature.
In all cases, install the thermostatic mixer (Fig. 5b on page 4) on the domestic hot water flow pipe which must not exceed 60° C. A mixer or mixing valve at each point of use is recommended.

2 - ON/OFF switch (item marked 2, Fig. 23)
This must be used to switch the boiler off before carrying out any work on it.

3 - Summer/Winter selector switch (item marked 3, Fig. 23)
“Winter” position: provides both domestic hot water and central heating functions. “Summer” position: The room thermostat or regulator (§ 2.2.4) is switched off. The central heating circulator is also switched off. Only the domestic hot water function is provided. You can use the thermostat (1) to reduce the temperature and save energy. If there is not enough hot water available, we recommend setting the thermostat (1) to its maximum value.
When the weather turns cold again, simply select “Winter” to reactivate the heating system.

4 - Thermometer (item marked 4, Fig. 23)
Reads the boiler primary circuit (central heating) temperature directly.

5 - Controller (item marked 5, Fig. 23)
Please refer to the enclosed instructions if you have chosen this option.

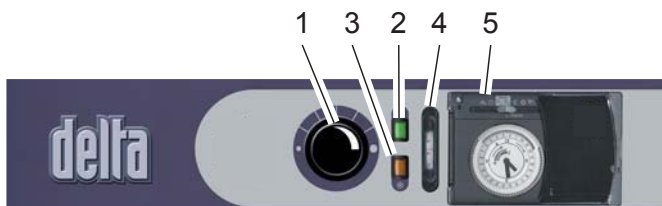

Fig. 23: Control panel

7.1.2 CENTRAL HEATING SYSTEM GAUGE PRESSURE

Your system is fitted with a central heating safety valve, set to 3 bar, which is fitted with a pressure gauge.
First make sure that the water in the system is still pressurised. When cold and after the air in the system has been bled, the pressure gauge should show a pressure of between 1 and 2, depending on the height of the building: (1 bar = 5m / 1.5 bar = 10 m and 2 bar = 15 m).
To add water, open the filling valve (Fig. 2 and 3 on page 3). Make sure the valve is properly closed after filling. Bleed the air in the system to get an accurate water pressure reading.

7.1.3 SAFETY VALVE (central heating) (item marked 2, Fig. 3 on page 3)



The water, which may flow out of the safety valve is very hot and may cause serious burns. The pipe discharging to waste water disposal system should be open to the atmosphere and installed in accordance with current regulations. Make sure there is nobody near the flow of hot water.

If you notice anything unusual after this short trial, please inform the installing engineer.

7.1.4 SAFETY UNIT (domestic hot water) (item marked 1, Fig. 5a and 5b on page 4)

A monthly inspection is recommended:
Lift the lever on the emptying device for a few seconds to ensure that the safety valve is working properly.



The water flowing out of the safety unit may be extremely hot. The pipe discharging to waste water disposal system should be open to the atmosphere and installed in accordance with current regulations. Make sure there is nobody near the flow of hot water.

If you notice anything unusual after this short trial, please inform the installing engineer.



Fig. 24: Oil burner reset button



If the burner is not working, isolate the electricity supply before attempting to reset the safety thermostat.

4. Remove the front panel and reset the safety thermostat located on the top of the boiler.



Wait until the boiler temperature drops below 60°C. Then replace the front panel.



Fig. 26: Safety thermostat reset button.

5. If the burner is working, replace the burner cover.
6. If the fault persists, please notify the installing engineer.

Starting the burners.

In normal operation, the gas burner starts up automatically provided that the boiler temperature falls below the set point.



To ensure your system operates properly, have it professionally serviced once a year before the cold weather starts.

7.1 BOILER ROOM

- Keep vents free at all times.
- Do not store any inflammable products in the boiler room.
- Take care not to store any corrosive products, such as paints, solvents, chlorine, salt, soap and other cleaning products, near the boiler.
- If you smell gas, do not switch on the light or light a flame. Turn off the mains gas tap at the meter and inform the appropriate services immediately.